

### INSTALLATION MANUAL

Achieve effortless architectural style with the cool, clean and contemporary lines of DecoBatten. The light-weight aluminium battens replicate the form, feel and appearance of real timber thanks to the Super Durable DecoWood finish, offering a dimensionally stable, long-lasting timber alternative. DecoBatten allows for complete design flexibility and is suitable for a wide range of applications.

#### DecoBatten Design Options

DecoBatten comes in two easy-to-install systems: the standard One-Piece system and a Two-Piece 'click' system. Both systems are available in a wide range of shapes and sizes and allow for multiple installation methods. One-Piece battens are generally used when fixing battens from behind and when fixings can be easily hidden. The Two-Piece 'click' system has been designed for easier and quicker installations of more difficult applications (walls, ceilings, etc) or where a seamless concealed fixing is desired.

#### Two-Piece Battens

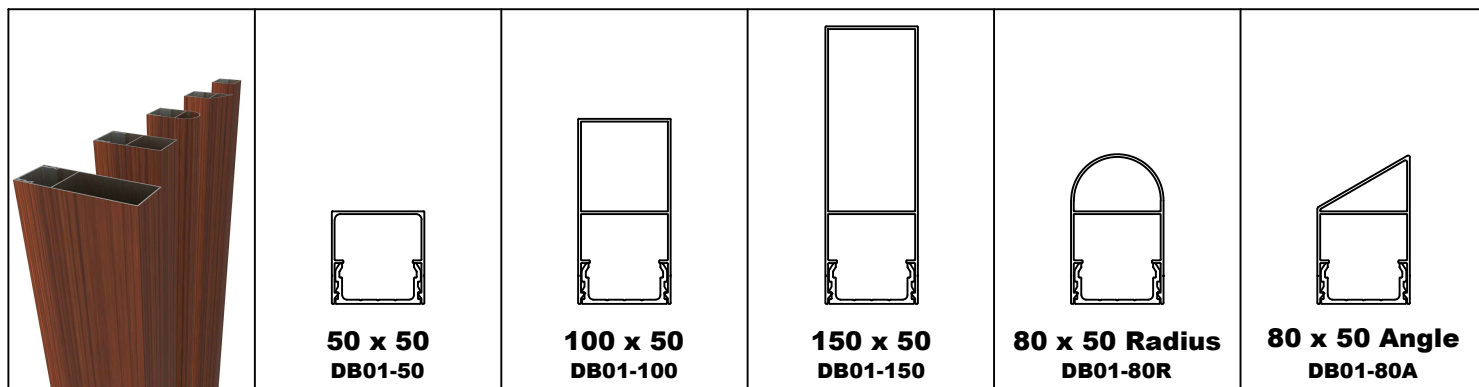

**Please Note** - The design of our Two-Piece batten systems may vary. The snap, fixing and securing detail of each system may vary based on the design and product availability. Please discuss the specific details of each design with your Deco Representative.

#### One-Piece Battens

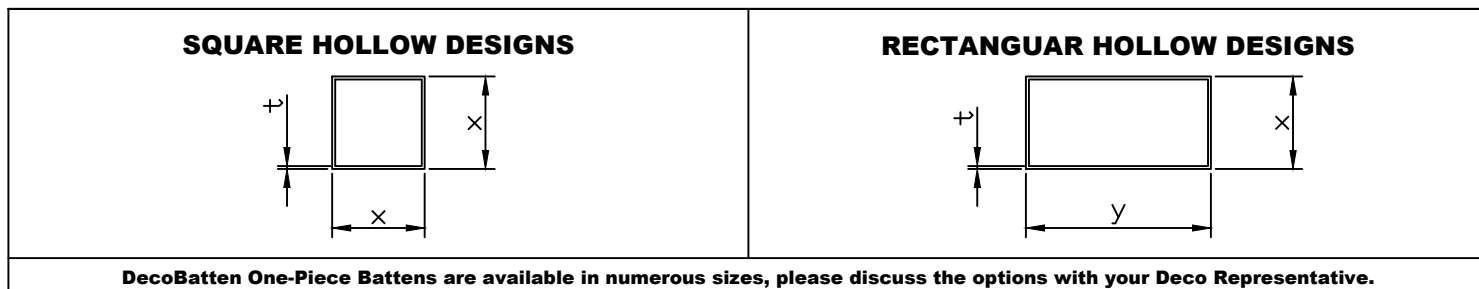

**DecoBatten One-Piece Battens are available in numerous sizes, please discuss the options with your Deco Representative.**

#### PERFORMANCE

As part of DECO's commitment to compliant building products, the DecoBatten systems have been designed to meet Australia's stringent building standards. The DecoBatten range has been tested to and passed the following standards:

DecoBatten - Tested Performance Data		
Description	Standard	Testing Body
Methods for fire tests on building materials, components and structures - Combustibility test for materials	AS1530.1	CSIRO
Methods for fire tests on building materials, components and structures - Simultaneous determination of ignitability, flame propagation, heat release and smoke release	AS/NZS1530.3	CSIRO
Method of test for heat and smoke release rates for materials and products using an oxygen consumption calorimeter	AS3837	CSIRO
DecoBatten - Assessed Performance Data		
Clause	Assessment Outcome	Assessment Body
NCC 2015 - Volume 1 - Clause C.1.12 - Combustibility of Materials (No Amendment in NCC 2016)	Compliant	CSIRO

**Please Note.** All testing has been undertaken using the detail provided in this installation manual and in order to claim the performances set out here within, the detail in this manual shall be followed.

#### ENGINEERING PERFORMANCE

Due to the extensive installation methods in which the DecoBatten systems can be applied, and the different requirements of each building type and location, it is recommended that users consult with their Architect, Engineer, Building Designer and Building Surveyor to ensure that the installation detail will suit the local regulations and requirements.

#### DecoBatten End Caps

As a part of the DecoBatten range, End Caps are available to match your chosen batten profile. End Caps are available in colour-matched aluminium or black plastic for both the One-Piece and Two-Piece batten systems. NB: Depending on the selected profile, End Caps will be one of two types; extruded aluminium for 50mm wide profiles or press-fit aluminium for all other profiles.

#### Extruded Aluminium End Caps

For all 50mm wide profiles, extruded aluminium End Caps are available in both the One-Piece and Two-Piece batten systems. Depending on the profile, the End Cap will be machined so that two legs fit into the profile and can be secured using a high quality adhesive or mechanical fixings.

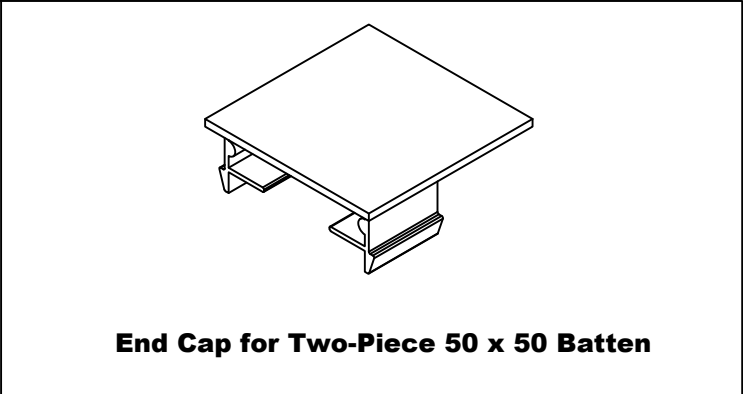
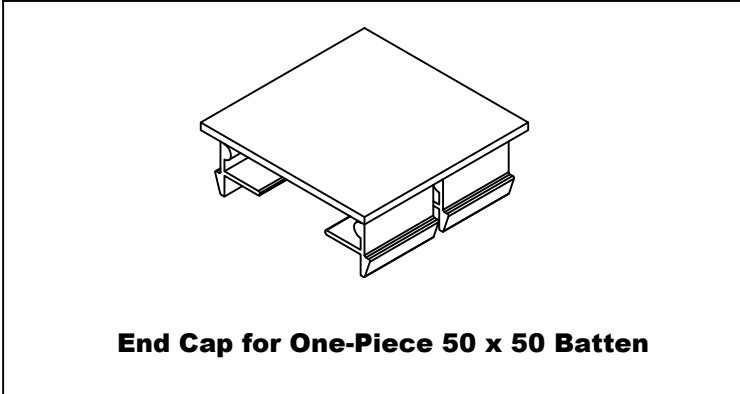

#### End Cap Securing

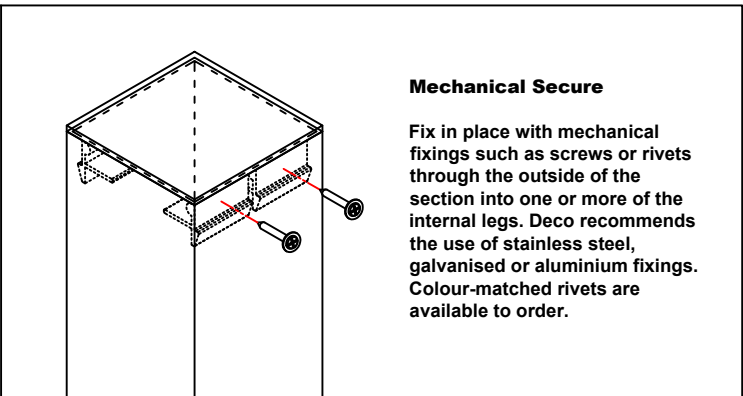
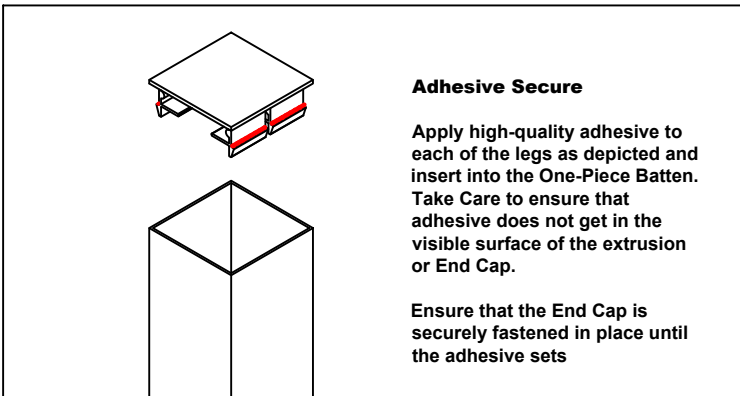

#### Press Fit Aluminium End Caps

For all other profiles, press-fit aluminium End Caps are available for both the One-Piece and Two-Piece batten systems. Depending on the profile, the End Cap will be machined so that it fits snug into the profile and can be secured using a high-quality adhesive.

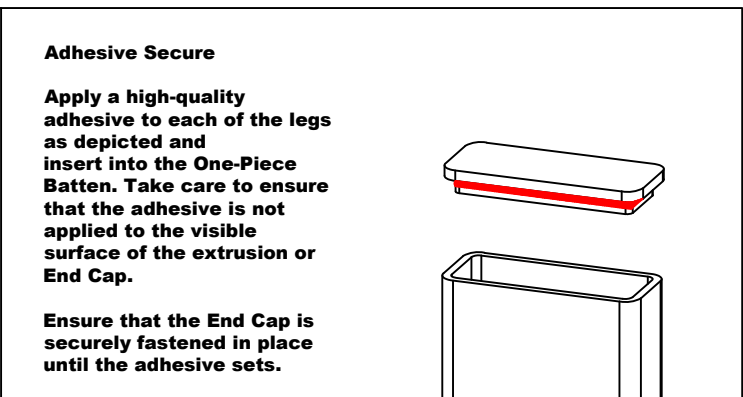
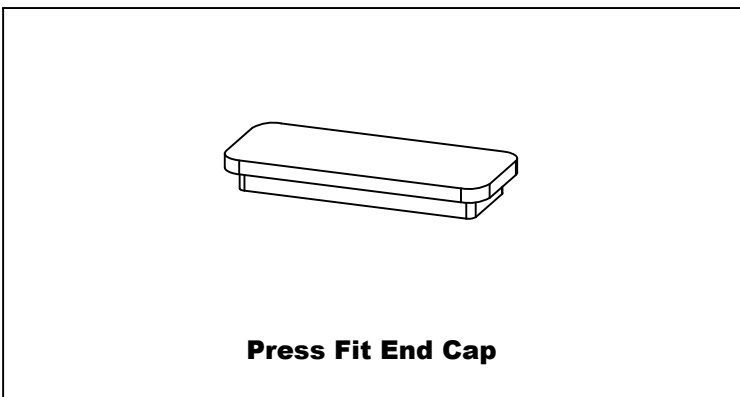

#### Preparation

##### Installation Surface

When installing DecoBatten care should be taken to ensure the installation surface has been prepared adequately to ensure that it is fit for the intended purpose. The surface should also be clean and flat, and preparations (such as backing colour) should be applied before the installation of DecoBatten Products.

##### Supporting Structure and Fixings

Before installing any DecoBatten products the supporting structure should be assessed to ensure that it is structurally sound and able to support live and dead loads of the DecoBatten products that are to be installed. When fixing DecoBatten products, it is recommended that they are fixed at minimum 600mm centres, however due to the wide variety of installation applications, this may not be required for all applications. DECO recommends that users contact a certified Engineer to assess the supporting structure and fixings required when installing DecoBatten, especially in high-wind and high-risk areas.

##### Processing of DecoBatten

**WARNING** - When processing DecoBatten care should be taken and appropriate Personal Protective Equipment should be worn at all times. Failure to do so risks potential serious injury, disablement or death. When processing DecoBattens, care should be taken to ensure that the work space is clean and free from dust, sawdust, metal fines and/or shavings. Processing of the DecoBatten in areas with excessive dust, sawdust, metal fines and/or shavings risks potential damage to the finished surface.

### STEP 1 - Apply the Two-Piece Batten Base to the Supporting Structure and Fix as Required.

If batten is to be installed flush to an end surface ensure at least 3mm of clearance to allow the batten cover to snap over the base.

To ensure a straight, consistent and parallel installation to is strongly recommended that a level is used to position each base.

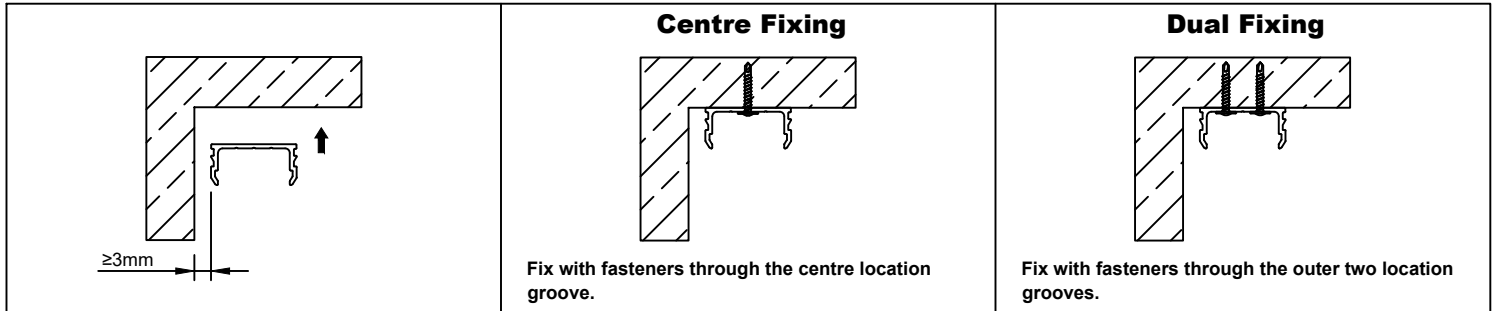

### STEP 2 - Install additional Two-Piece Bases and Fix as Required.

To ensure equal consistent spacing between each batten, space the bases according to your desired finished spacing and the below formula.

1. X (between bases spacing) = Desired finished spacing + 4mm
2. Y (centre to centre spacing) = Desired finished spacing + 50mm

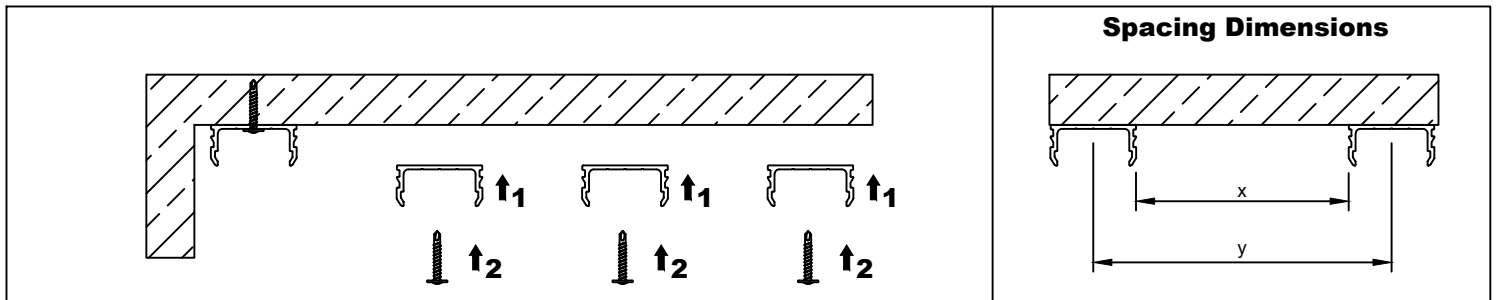

### STEP 3 - Install Two-Piece Covers and Fix as Required.

Snap the cover over each of the bases, ensuring a tight fit. Even though the Deco Batten product has been designed to ensure a secure snap fit, if extra security against dislodgement is required, follow the detail provided below.

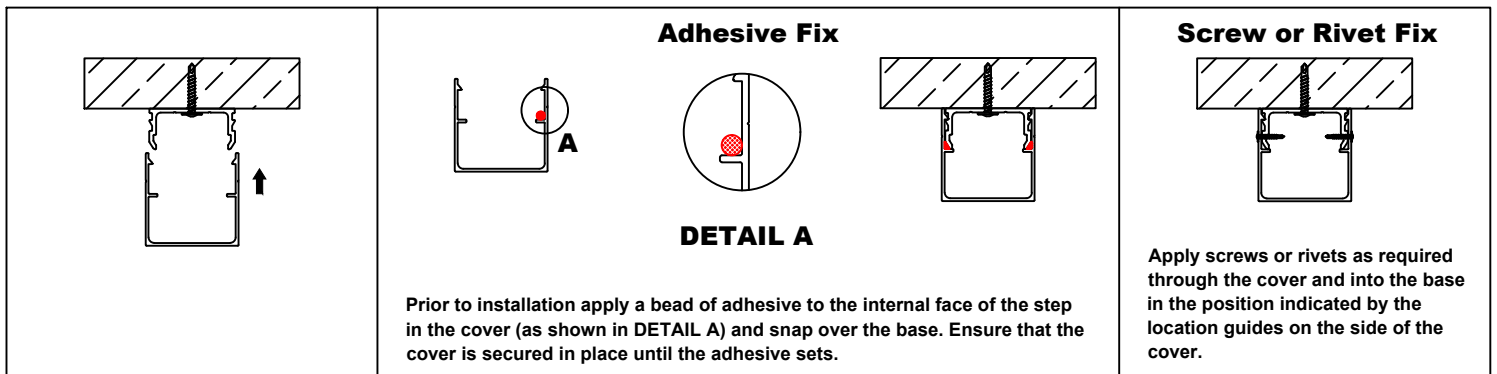

### INSTALLATION MANUAL

#### One-Piece Batten Fixing Options

#### Back Fixing

The simplest method of fixing One-Piece battens is to fix through the back of support material into the extrusion.

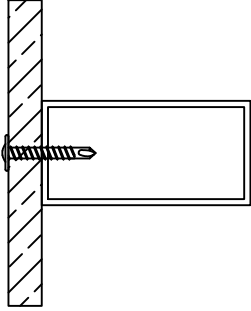

#### Bolt Fixing

Bolt Fixing allows connection of materials at any angle, or interval. Bolt Fixing also allows on site construction of factory processed materials for a quick assembly and installation. When tightening bolt ensure that they are not over tightened as this may cause the extrusion to deform.

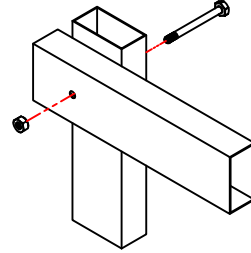

#### Fixed Surface Angle Fixing

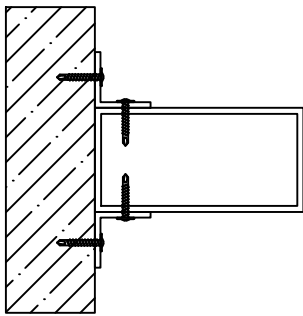

#### Fixed Surface Channel Fixing

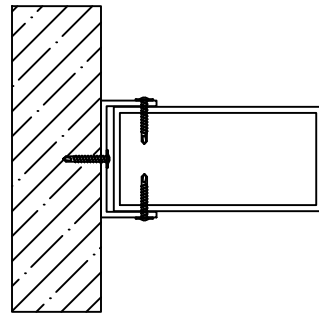

#### End to End Angle Fixing

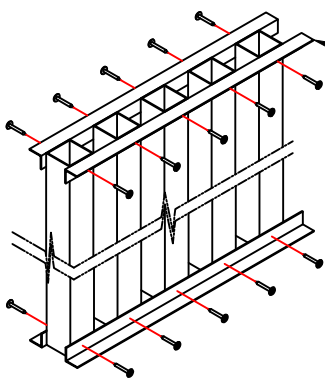

Front angle may be optional, based on the the specific site requirements or construction detail. Check Engineers specifications

#### End to End Channel Fixing

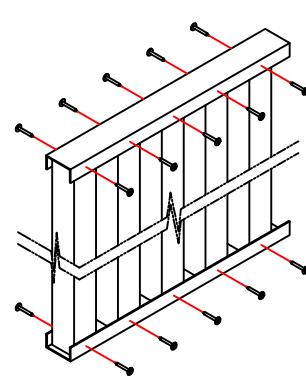

### WARRANTY FOR DECO PRODUCTS AND FINISHES

Deco warrants that Deco finishes have been applied in accordance with the Australian Standard for Architectural Powder Coating AS 3715. The warranty is for 12 years and is subject to the provisions set out in AS 3715, including maintenance and cleaning, as set out in Appendix C of the standard.

Please note that if a formal warranty certificate is required, then this must be applied for at the time of placing the order. This is because the standard requires Deco to process specimens for testing and reference, at the same time as the job is processed. A warranty application form can be obtained by contacting Deco by phone or email.

Contact your DECO Representative on (02) 9726 7726 for more information.